



 Anupam metals India

Shine across the world



Buttweld Fittings

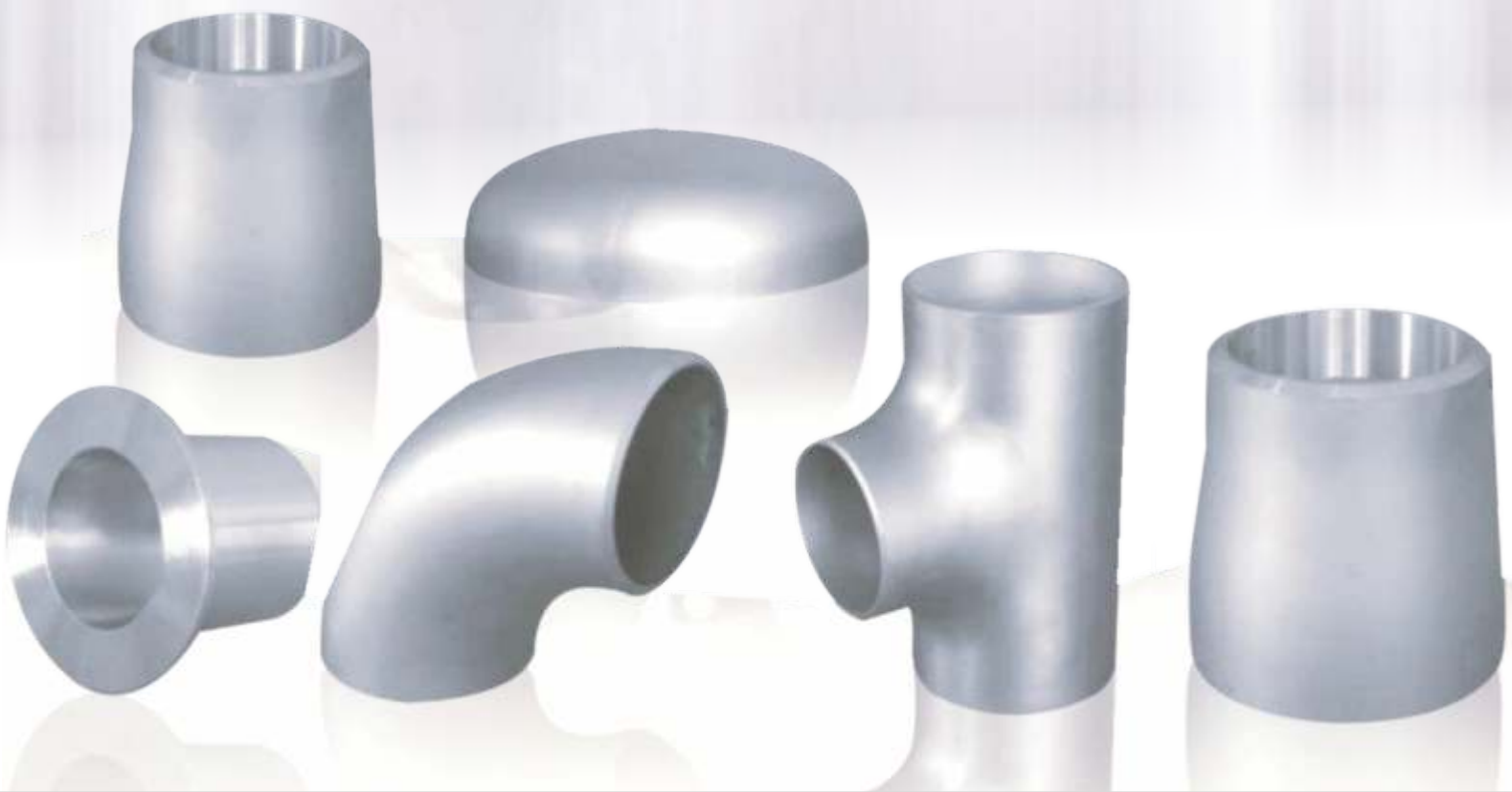

ASTM A403 Fitting Classes for WP Grades

Class	Construction	Nondestructive Examination
S	Seamless	None
W	Welded	Radiography or Ultrasonic
WX	Welded	Radiography
WU	Welded	Ultrasonic

Chemical Requirements

NOTE 1—Where an ellipsis (...) appears in this table, there is no requirement.

Grade			Composition, %										
Grade WP	Grade CR	UNSDesignation	C ^B	Mn ^B	P ^B	S ^B	Si ^B	Ni	Cr	Mo	Ti	N2C ^C	Others
WPXM-19	CRXM-19	S20910	0.06	4.0–6.0	0.045	0.030	1.00	11.5–13.5	20.5–23.5	1.50–3.00	...	0.20–0.40	D
WP304	CR304	S30400	0.08	2.00	0.045	0.030	1.00	8.0–11.0	18.0–20.0
WP304L	CR304L	S30403	0.030 ^E	2.00	0.045	0.030	1.00	8.0–12.0	18.0–20.0
WP304H	CR304H	S30409	0.04–0.10	2.00	0.045	0.030	1.00	8.0–11.0	18.0–20.0
WP304N	CR304N	S30451	0.08	2.00	0.045	0.030	1.00	8.0–11.0	18.0–20.0	0.10–0.16	...
WP304LN	CR304LN	S30453	0.030	2.00	0.045	0.030	1.00	8.0–11.0	18.0–20.0	0.10–0.16	...
WP309	CR309	S30900	0.20	2.00	0.045	0.030	1.00	12.0–15.0	22.0–24.0
WP310S	CR310S	S31008	0.08	2.00	0.045	0.030	1.00	19.0–22.0	24.0–26.0
WPS31254	CRS31254	S31254	0.020	1.00	0.030	0.010	0.80	17.5–18.5	19.5–20.5	6.0–6.5	...	0.18–0.22	Cu 0.50–1.00
WP316	CR316	S31600	0.08	2.00	0.045	0.030	1.00	10.0–14.0	16.0–18.0	2.00–3.00
WP316L	CR316L	S31603	0.030 ^E	2.00	0.045	0.030	1.00	10.0–14.0 ^F	16.0–18.0	2.00–3.00
WP316H	CR316H	S31609	0.04–0.10	2.00	0.045	0.030	1.00	10.0–14.0	16.0–18.0	2.00–3.00
WP316N	CR316N	S31651	0.08	2.00	0.045	0.030	1.00	10.0–13.0	16.0–18.0	2.00–3.00	...	0.10–0.16	...
WP316LN	CR316LN	S31653	0.030	2.00	0.045	0.030	1.00	10.0–13.0	16.0–18.0	2.00–3.00	...	0.10–0.16	...
WP317	CR317	S31700	0.08	2.00	0.045	0.030	1.00	11.0–15.0	18.0–20.0	3.0–4.0
WP317L	CR317L	S31703	0.030	2.00	0.045	0.030	1.00	11.0–15.0	18.0–20.0	3.0–4.0
WPS31725	CRS31725	S31725	0.030	2.00	0.045	0.030	1.00	13.5–17.5	18.0–20.0	4.0–5.0	...	0.20	...
WPS31726	CRS31726	S31726	0.030	2.00	0.045	0.030	1.00	13.5–17.5	17.0–20.0	4.0–5.0	...	0.10–0.20	...
WPS31727	CRS31727	S31727	0.030	1.00	0.030	0.030	1.00	14.5–16.5	17.5–19.0	3.8–4.5	...	0.15–0.21	Cu 2.8–4.0
WPS32053	CRS32053	S32053	0.030	1.00	0.030	0.010	1.00	24.0–26.0	22.0–24.0	5.0–6.0	...	0.17–0.22	...
WP321	CR321	S32100	0.08	2.00	0.045	0.030	1.00	9.0–12.0	17.0–19.0	...	G
WP321H	CR321H	S32109	0.04–0.10	2.00	0.045	0.030	1.00	9.0–12.0	17.0–19.0	...	H
WPS33228	CRS33228	S33228	0.04–0.08	1.00	0.020	0.015	0.30	31.0–33.0	26.0–28.0	Ce 0.05–0.10 Al 0.025 Cb 0.6–1.0 Cb 0.10
WPS34565	CRS34565	S34565	0.030	5.0–7.0	0.030	0.010	1.00	16.0–18.0	23.0–25.0	4.0–5.0	...	0.40–0.60	...
WP347	CR347	S34700	0.08	2.00	0.045	0.030	1.00	9.0–12.0	17.0–19.0	I
WP347H	CR347H	S34709	0.04–0.10	2.00	0.045	0.030	1.00	9.0–12.0	17.0–19.0	J
WP348	CR348	S34800	0.08	2.00	0.045	0.030	1.00	9.0–12.0	17.0–19.0	Cb+Ta=103(C)–1.10 Ta 0.10 Co 0.20
WP348H	CR348H	S34809	0.04–0.10	2.00	0.045	0.030	1.00	9.0–12.0	17.0–19.0	Cb+Ta=83(C)–1.10 Ta 0.10 Co 0.20
WPS38815	CRS38815	S38815	0.030	2.00	0.040	0.020	5.5–6.5	13.0–17.0	13.0–15.0	0.75–1.50	Cu 0.75–1.50 Al 0.30

B Maximum, unless otherwise indicated.

C The method of analysis for nitrogen shall be a matter of agreement between the purchaser and manufacturer.

D Columbium 0.10–0.30 %; Vanadium, 0.10–0.30 %.

E For small diameter or thin walls, or both, where many drawing passes are required, a carbon maximum of 0.040 % is necessary in grades TP304L and TP316L. Small outside diameter tubes are defined as those less than 0.500 in. [12.7 mm] in outside diameter and light wall tubes as those less than 0.049 in. [1.24 mm] in average wall thickness.

F On pierced tubing, the nickel may be 11.0–16.0 %.

G 5X(C+N2)–0.70.

H 4X(C+N2)–0.70.

I The columbium content shall be not less than ten times the carbon content and not more than 1.10 %.

J The columbium content shall be not less than eight times the carbon content and not more than 1.10 %.

Common Names

Grade WP ^A	Grade CR ^A	UNS	DesignationType ^B
WPXM-19	CRXM-19	S20910	XM-19C
WP304	CR304	S30400	304
WP304L	CR304L	S30403	304L
WP304H	CR304H	S30409	304H
WP304N	CR304N	S30451	304N
WP304LN	CR304LN	S30453	304LN
WP309	CR309	S30900	309
WP310S	CR310S	S31008	310S
WPS31254	CRS31254	S31254	...
WP316	CR316	S31600	316
WP316L	CR316L	S31603	316L
WP316H	CR316H	S31609	316H
WP316N	CR316N	S31651	316N
WP316LN	CR316LN	S31653	316LN
WP317	CR317	S31700	317
WP317L	CR317L	S31703	317L
WPS31725	CRS31725	S31725	317LMC
WPS31726	CRS31726	S31726	317LMNC
WPS31727	CRS31727	S31727	...
WPS32053	CRS32053	S32053	...
WP321	CR321	S32100	321
WP321H	CR321H	S32109	321H
WPS33228	CRS33228	S33228	...
WPS34565	CRS34565	S34565	...
WP347	CR347	S34700	347
WP347H	CR347H	S34709	347H
WP348	CR348	S34800	348
WP348H	CR348H	S34809	348H
WPS38815	CRS38815	S38815	...

^A Naming system developed and applied by ASTM International.

^B Unless otherwise indicated, a grade designation originally assigned by the C.American Iron and Steel Institute (AISI).

^C Common name, not a trademark widely used, not associated with any one producer.

Heat Treatment For Wrought Stainless Steel Pipe Fittings

Grade WPA	Grade CRA	UNS Designation	Solution Anneal Temperature, min° F [°C] ^B	Quench Media
WPXM-19	CRXM-19	S20910	1900 [1040]	water or other rapid cool
WP304	CR304	S30400	1900 [1040]	water or other rapid cool
WP304L	CR304L	S30403	1900 [1040]	water or other rapid cool
WP304H	CR304H	S30409	1900 [1040]	water or other rapid cool
WP304N	CR304N	S30451	1900 [1040]	water or other rapid cool
WP304LN	CR304LN	S30453	1900 [1040]	water or other rapid cool
WP309	CR309	S30900	1900 [1040]	water or other rapid cool
WP310S	CR310S	S31008	1900 [1040]	water or other rapid cool
WPS31254	CR31254	S31254	2100 [1150]	water or other rapid cool
WP316	CR316	S31600	1900 [1040]	water or other rapid cool
WP316L	CR316L	S31603	1900 [1040]	water or other rapid cool
WP316H	CR316H	S31609	1900 [1040]	water or other rapid cool
WP316N	CR316N	S31651	1900 [1040]	water or other rapid cool
WP316LN	CR316LN	S31653	1900 [1040]	water or other rapid cool
WP317	CR317	S31700	1900 [1040]	water or other rapid cool
WP317L	CR317L	S31703	1900 [1040]	water or other rapid cool
WPS31725	CRS31725	S31725	1900 [1040]	water or other rapid cool
WPS31726	CRS31726	S31726	1900 [1040]	water or other rapid cool
WPS31727	CRS31727	S31727	1975–2155 [1080–1180]	water or other rapid cool
WPS32053	CRS32053	S32053	1975–2155 [1080–1180]	water or other rapid cool
WP321	CR321	S32100	1900 [1040]	water or other rapid cool
WP321H	CR321H	S32109	1925 [1050]	water or other rapid cool
WPS33228	CRS33228	S33228	2050–2160 [1120–1180]	water or other rapid cool
WPS34565	CRS34565	S34565	2050–2140 [1120–1170]	water or other rapid cool
WP347	CR347	S34700	1900 [1040]	water or other rapid cool
WP347H	CR347H	S34709	1925 [1050]	water or other rapid cool
WP348	CR348	S34800	1900 [1040]	water or other rapid cool
WP348H	CR348H	S34809	1925 [1050]	water or other rapid cool
WPS38815	CRS38815	S38815	1950 [1065]	water or other rapid cool

Tensile Requirements For Wrought Stainless Steel Pipe Fittings

All WP and CR Grades	Yield Strength, min, ksi [MPa]	Tensile Strength, min, ksi [MPa]
304,304LN,304H,309, 310S, 316, 316LN,316H, 317, 317L, 321, 321H, 347, 347H, 348, 348H	30 [205]	75 [515]
S31725		
S31727	36 [245]	80 [550]
S32053	43 [295]	93 [640]
304L,316L	25 [170]	70 [485]
304N, 316N, S31726	35 [240]	80 [550]
XM-19	55 [380]	100 [690]
S31254	44 [300]	94 [650] to 119 [820]
S33228	27 [185]	73 [500]
S34565	60 [415]	115 [795]
S38815	37 [255]	78 [540]
	Elongation Requirements	
	Longitudinal	Transverse
Standard round specimen, or small proportional specimen, or striptype specimen, minimum % in 4 D [^]	28	20

[^] S38815 Elongation in 2 in. — 30 % min.

**ASTM A234
Chemical Requirements**

NOTE1—All Requirements Are Maximum Unless Otherwise Indicated. Note2—where An Ellipsis (...) Appears In This Table, There Is No Requirement.

Grade and Marking Symbol ^A	Composition, %									
	Carbon	Manganese	Phosphorus, max	Sulfur, max	Silicon	Chromium	Molybdenum	Nickel	Copper	Others
WPB ^{B,C,D,E,F}	0.30max	0.29–1.06	0.050	0.058	0.10min	0.40max	0.15max	0.40max	0.40max	Vanadium 0.08max
WPC ^{C,D,E,F}	0.35max	0.29–1.06	0.050	0.058	0.10min	0.40max	0.15max	0.40max	0.40max	Vanadium 0.08max
WP1	0.28max	0.30–0.90	0.045	0.045	0.10–0.50	...	0.44–0.65
WP12 CL1, WP12 CL2	0.05–0.20	0.30–0.80	0.045	0.045	0.60max	0.80–1.25	0.44–0.65
WP11 CL1	0.05–0.15	0.30–0.60	0.030	0.030	0.50–1.00	1.00–1.50	0.44–0.65
WP11 CL2, WP11 CL3	0.05–0.20	0.30–0.80	0.040	0.040	0.50–1.00	1.00–1.50	0.44–0.65
WP22 CL1, WP22 CL3	0.05–0.15	0.30–0.60	0.040	0.040	0.50max	1.90–2.60	0.87–1.13
WP5 CL1, WP5 CL3	0.15max	0.30–0.60	0.040	0.030	0.50max	4.0–6.0	0.44–0.65
WP9 CL1, WP9 CL3	0.15 max	0.30–0.60	0.030	0.030	1.00 max	8.0–10.0	0.90–1.10
WPR	0.20max	0.40–1.06	0.045	0.050	1.60–2.24	0.75–1.25	...
WP91	0.08–0.12	0.30–0.60	0.020	0.010	0.20–0.50	8.0–9.5	0.85–1.05	0.40max	...	Vanadium 0.18–0.25 Columbium 0.06–0.10 Nitrogen 0.03–0.07 Aluminum 0.02max ^G Titanium 0.01max ^G Zirconium 0.01max ^G
WP911	0.09–0.13	0.30–0.60	0.020	0.010	0.10–0.50	8.5–9.5	0.90–1.10	0.40max	...	Vanadium 0.18–0.25 Columbium 0.060–0.10 Nitrogen 0.04–0.09 Aluminum 0.02max ^G Boron 0.0003–0.006 Tungsten 0.90–1.10 Titanium 0.01max ^G Zirconium 0.01max ^G

^A When fittings are of welded construction, the grade and marking symbol shown above shall be supplemented by letter "W".

^B Fittings made from bar or plate may have 0.35 max carbon.

^C Fittings made from forgings may have 0.35 max carbon and 0.35 max silicon with no minimum.

^D For each reduction of 0.01 % below the specified carbon maximum, an increase of 0.06 % manganese above the specified maximum will be permitted, up to a maximum of 1.35 %.

^E The sum of Copper, Nickel, Chromium, and Molybdenum shall not exceed 1.00 %.

^F The sum of Chromium and Molybdenum shall not exceed 0.32 %.

^G Applies both to heat and product analyses.

Note :

For grades WPB and WPC, the maximum carbon equivalent (C.E.), based on heat analysis and the following formula, shall be 0.50.

$$C.E. = C + \frac{Mn}{6} + \frac{Cr+Mo+V}{5} + \frac{Ni + Cu}{15}$$

A lower maximum carbon equivalent may be agreed upon between the purchaser and the supplier. The C.E. shall be reported on the test report.

Tensile Requirements For Wrought Carbon Steel & Alloy Steel Pipe Fittings

Grade and Marking Symbol	WPB	WPC, WP11 CL2, WP12 CL2 WP9 CL1	WP1	WP11 CL1, WP22 CL1, WP5 CL1	WPR	WP11 CL3, WP22 CL3 WP5 CL3 WP9 CL3	WP91	WP911	WP12 CL1
Tensile strength, range ksi [MPa]	60–95 [415–655]	70–95 [485–655]	55–80 [380–550]	60–85 [415–585]	63–88 [435–605]	75–100 [520–690]	85–110 [585–760]	90–120 [620–840]	60–85 [415–585]
Yield strength, min, ksi [MPa] (0.2 % offset or 0.5 % extension under load)	35[240]	40[275]	30[205]	30[205]	46[315]	45[310]	60[415]	64[440]	32[220]
Elongation Requirements									
Grades									
All Grades except WPR, WP91, and WP911						WPR		WP91 WP911	
		Longi- tudinal		Trans- verse		Longi- tudinal		Trans- verse	
Elongation: Standard round specimen, or small proportional specimen, min % in 4 D				22	14	20	...	20	...
Rectangular specimen for wall thickness 5/16 in. [7.94 mm] and over, and for all small sizes tested in full section; min % in 2 in. [50 mm]				30	20A	28
Rectangular specimen for wall thickness less than 5/16 in. [7.94 mm]; min % in 2 in. [50 mm] (1/2-in. [12.7-mm] wide specimen)				B	B	B
A WPB and WPC fittings manufactured from plate shall have a minimum elongation of 17 %. B For each 1/32 in. [0.79 mm] decrease in wall thickness below 5/16 in. [7.94 mm], a deduction of 1.5 % for longitudinal and 1.0 % for transverse from the values shown above is permitted. The following table gives the minimum value for various wall thicknesses.									
Wall thicknesses		Grades							
		All Grades except WPR, WP91 and WP911			WPR		WP91 and WP911		
in.	[mm]	Longitudinal		Transverse		Longitudinal		Longitudinal	
5/16 (0.312)	7.94	30.0	20.0	28.0	20				
9/32 (0.281)	7.14	28.5	19.0	26.5	19				
1/4 (0.250)	6.35	27.0	18.0	25.0	18				
7/32 (0.219)	5.56	25.5	...	23.5	17				
3/16 (0.188)	4.76	24.0	...	22.0	16				
5/32 (0.156)	3.97	22.5	...	20.5	15				
1/8 (0.125)	3.17	21.0	...	19.0	14				
3/32 (0.094)	2.38	19.5	...	17.5	13				
1/16 (0.062)	1.59	18.0	...	16.0	12				

Note—This table gives the computed minimum % elongation value for each 1/32 in. [0.79 mm] decrease in wall thickness. Where the wall thickness lies between two

values above, the minimum elongation value is determined by the following equations:

Direction of Test

Longitudinal

Transverse

Equation

E = 48t + 15.00

E = 32t + 10.00

where:

E = elongation in 2 in. or [50 mm], %, and

t = actual thickness of specimen, in. [mm].

Fitting Designation for Marking Purposes

Grade	Class	Construction	Mandatory Marking
WPB		W (Welded construction)	WPBWA
		S (Seamless construction)	WPB
WPC		W (Welded construction)	WPCWA
		S (Seamless construction)	WPC
WP1		W (Welded construction)	WP1WA
		S (Seamless construction)	WP1
WP12	CL1	W (Welded construction)	WP12CL1WA
		S (Seamless construction)	WP12CL1
	CL2	W (Welded construction)	WP12CL2WA
		S (Seamless construction)	WP12CL2
WP11	CL1	W (Welded construction)	WP11CL1WA
		S (Seamless construction)	WP11CL1
	CL2	W (Welded construction)	WP11CL2WA
		S (Seamless construction)	WP11CL2
	CL3	W (Welded construction)	WP11CL3WA
		S (Seamless construction)	WP11CL3
WP22	CL1	W (Welded construction)	WP22CL1WA
		S (Seamless construction)	WP22CL1
	CL3	W (Welded construction)	WP22CL3WA
		S (Seamless construction)	WP22CL3
WP5	CL1	W (Welded construction)	WP5CL1WA
		S (Seamless construction)	WP5CL1
	CL3	W (Welded construction)	WP5CL3WA
		S (Seamless construction)	WP5CL3
WP9	CL1	W (Welded construction)	WP9CL1WA
		S (Seamless construction)	WP9CL1
	CL3	W (Welded construction)	WP9CL3WA
		S (Seamless construction)	WP9CL3
WPR		W (Welded construction)	WPRWA
		S (Seamless construction)	WPR
WP91		W (Welded construction)	WP91WA
		S (Seamless construction)	WP91

^Add "U" to marking if welds are ultrasonic inspected in lieu of radiography.

ASME B16.9

Dimensions of Long Radius Elbows

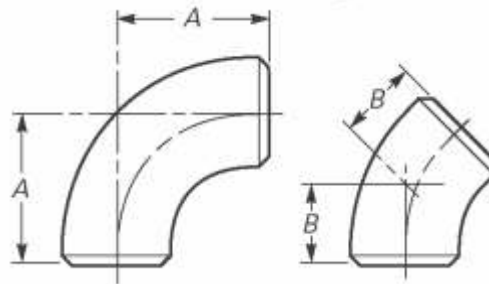

Nominal Pipe Size (NPS)	Outside Diameter at Bevel	Center-to-End	
		90-deg Elbows, A	45-deg Elbows, B
1/2	21.3	38	16
3/4	26.7	38	19
1	33.4	38	22
1 1/4	42.2	48	25
1 1/2	48.3	57	29
2	60.3	76	35
2 1/2	73.0	95	44
3	88.9	114	51
3 1/2	101.6	133	57
4	114.3	152	64
5	141.3	190	79
6	168.3	229	95
8	219.1	305	127
10	273.0	381	159
12	323.8	457	190
14	355.6	533	222
16	406.4	610	254
18	457.0	686	286
20	508.0	762	318
22	559.0	838	343
24	610.0	914	381
26	660.0	991	406
28	711.0	1 067	438
30	762.0	1 143	470
32	813.0	1 219	502
34	864.0	1 295	533
36	914.0	1 372	565
38	965.0	1 448	600
40	1 016.0	1 524	632
42	1 067.0	1 600	660
44	1 118.0	1 676	695
46	1 168.0	1 753	727
48	1 219.0	1 829	759

GENERAL NOTE: All dimensions are in millimeters.

ASME B16.9
Dimensions of Long Radius Reducing Elbows

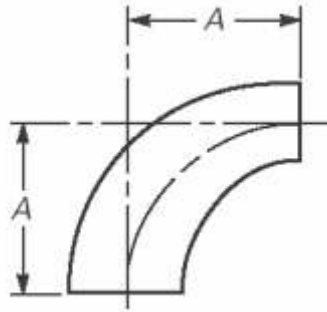

Nominal Pipe Size (NPS)	Outside Diameter at Bevel		Center-to-End, A	Nominal Pipe Size (NPS)	Outside Diameter at Bevel		Center-to-End, A
	Large End	Small End			Large End	Small End	
2 X 1 ½	60.3	48.3	76	10 x 8	273.0	219.1	381
2 X 1 ¼	60.3	42.2	76	10 x 6	273.0	168.3	381
2 X 1	60.3	33.4	76	10 X 5	273.0	141.3	381
2 ½ X 2	73.0	60.3	95	12 X 10	323.8	273.0	457
2 ½ X 1 ½	73.0	48.3	95	12 X 8	323.8	219.1	457
2 ½ X 1 ¼	73.0	42.2	95	12 X 6	323.8	168.3	457
3 X 2 ½	88.9	73.0	114	14 X 12	355.6	323.8	533
3 X 2	88.9	60.3	114	14 X 10	355.6	273.0	533
3 X 1 ½	88.9	48.3	114	14 X 8	355.6	219.1	533
3 ½ X 3	101.6	88.9	133	16 X 14	406.4	355.6	610
3 ½ X 2 ½	101.6	73.0	133	16 X 12	406.4	323.8	610
3 ½ X 2	101.6	60.3	133	16 X 10	406.4	273.0	610
4 X 3 ½	114.3	101.6	152	18 X 16	457.0	406.4	686
4 X 3	114.3	88.9	152	18 X 14	457.0	355.6	686
4 X 2 ½	114.3	73.0	152	18 X 12	457.0	323.8	686
4 X 2	114.3	60.3	152	18 X 10	457.0	273.0	686
5 X 4	141.3	114.3	190	20 X 18	508.0	457.0	762
5 X 3 ½	141.3	101.6	190	20 X 16	508.0	406.4	762
5 X 3	141.3	88.9	190	20 X 14	508.0	355.6	762
5 X 2 ½	141.3	73.0	190	20 X 12	508.0	323.8	762
				20 X 10	508.0	273.0	762
6 x 5	168.3	141.3	229	24 X 22	610.0	559.0	914
6 X 4	168.3	114.3	229	24 X 20	610.0	508.0	914
6 X 3 ½	168.3	101.6	229	24 X 18	610.0	457.0	914
6 X 3	168.3	88.9	229	24 X 16	610.0	406.4	914
				24 X 14	610.0	355.6	914
8 x 6	219.3	168.3	305	24 X 12	610.0	323.8	914
8 X 5	219.1	141.3	305
8 x 4	219.1	114.3	305				

GENERAL NOTE: All dimensions are in millimeters.

ASME B16.9

Dimensions of Long Radius Returns

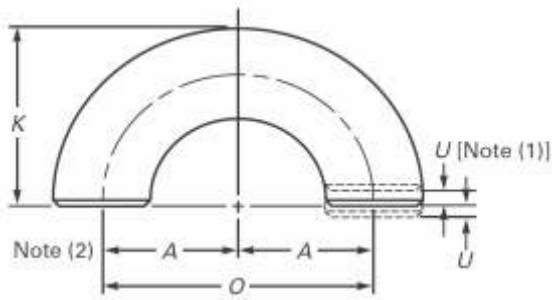

Dimensions of Short Radius Elbows

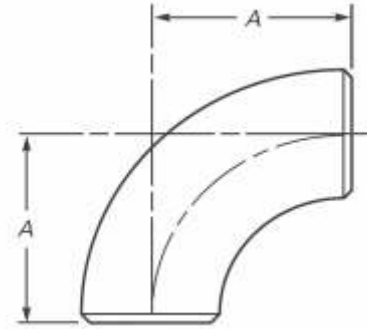

Nominal Pipe Size (NPS)	Outside Diameter at Bevel	Center-to-Center, O	Back-to-Face, K
1/2	21.3	76	48
3/4	26.7	76	51
1	33.4	76	56
1 1/4	42.2	95	70
1 1/2	48.3	114	83
2	60.3	152	106
2 1/2	73.0	190	132
3	88.9	229	159
3 1/2	101.6	267	184
4	114.3	305	210
5	141.3	381	262
6	168.3	457	313
8	219.1	610	414
10	273.0	762	518
12	323.8	914	619
14	355.6	1 067	711
16	406.4	1 219	813
18	457.0	1 372	914
20	508.0	1 524	1 016
22	559.0	1 676	1 118
24	610.0	1 829	1 219

Nominal Pipe Size (NPS)	Outside Diameter at Bevel	Center-to-End, A
1	33.4	25
1 1/4	42.2	32
1 1/2	48.3	38
2	60.3	51
2 1/2	73.0	64
3	88.9	76
3 1/2	101.6	89
4	114.3	102
5	141.3	127
6	168.3	152
8	219.1	203
10	273.0	254
12	323.8	305
14	355.6	356
16	406.4	406
18	457.0	457
20	508.0	508
22	559.0	559
24	610.0	610

GENERAL NOTE: All dimensions are in millimeters.

GENERAL NOTE: All dimensions are in millimeters.



Dimensions of Short Radius 180-deg Returns **ASME B16.9**

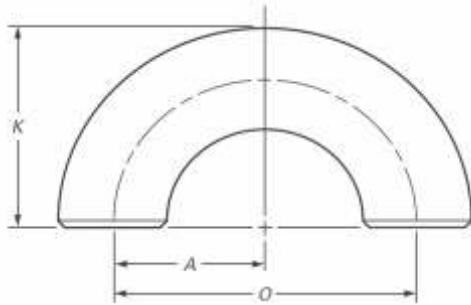

Nominal Pipe Size (NPS)	Outside Diameter at Bevel	Center-to-Center, O	Back-to-Face, K
1	33.4	51	41
1¼	42.2	64	52
1½	48.3	76	62
2	60.3	102	81
2½	73.0	127	100
3	88.9	152	121
3½	101.6	178	140
4	114.3	203	159
5	141.3	254	197
6	168.3	305	237
8	219.1	406	313
10	273.0	508	391
12	323.8	610	467
14	355.6	711	533
16	406.4	813	610
18	457.0	914	686
20	508.0	1 016	762
22	559.0	1 118	838
24	610.0	1 219	914

GENERAL NOTES:

- (a) All dimensions are in millimeters.
- (b) Dimension A is equal to one-half of dimension O.

Dimensions of 3D Elbows

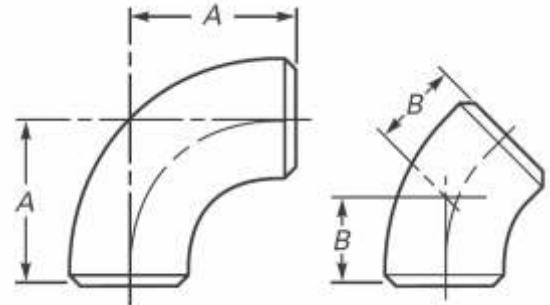

Nominal Pipe Size (NPS)	Outside Diameter at Bevel	Center - to - End	
		90-deg Elbows, A	45-deg Elbows, B
¾	26.7	57	24
1	33.4	76	31
1¼	42.2	95	39
1½	48.3	114	47
2	60.3	152	63
2½	73.0	190	79
3	88.9	229	95
3½	101.6	267	111
4	114.3	305	127
5	141.3	381	157
6	168.3	457	189
8	219.1	610	252
10	273.0	762	316
12	323.8	914	378
14	355.6	1 067	441
16	406.4	1 219	505
18	457.0	1 372	568
20	508.0	1 524	632
22	559.0	1 676	694
24	610.0	1 829	757
26	660.0	1 981	821
28	711.0	2 134	883
30	762.0	2 286	964
32	813.0	2 438	1 010
34	864.0	2 591	1 073
36	914.0	2 743	1 135
38	965.0	2 896	1 200
40	1 016.0	3 048	1 264
42	1 067.0	3 200	1 326
44	1 118.0	3 353	1 389
46	1 168.0	3 505	1 453
48	1 219.0	3 658	1 516

GENERAL NOTE: All dimensions are in millimeters.

ASME B16.9
Dimensions of Straight Tees and Crosses

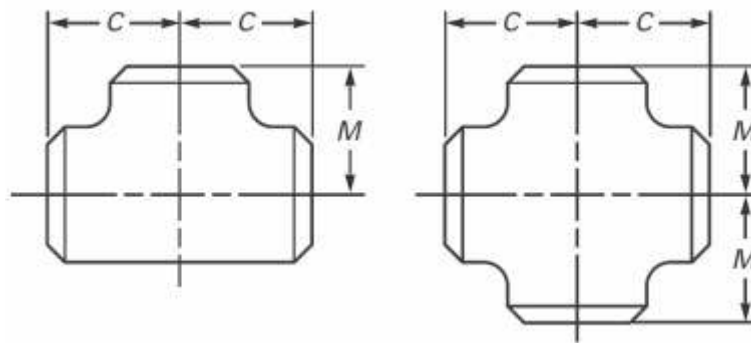

Nominal Pipe Size (NPS)	Outside Diameter at Bevel	Center - to - End	
		RUN, C	Outlet, M [Notes (1) and (2)]
½	21.3	25	25
¾	26.7	29	29
1	33.4	38	38
1¼	42.2	48	48
1½	48.3	57	57
2	60.3	64	64
2½	73.0	76	76
3	88.9	86	86
3½	101.6	95	95
4	114.3	105	105
5	141.3	124	124
6	168.3	143	143
8	219.1	178	178
10	273.0	216	216
12	323.8	254	254
14	355.6	279	279
16	406.4	305	305
18	457.0	343	343
20	508.0	381	381
22	559.0	419	419
24	610.0	432	432
26	660.0	495	495
28	711.0	521	521
30	762.0	559	559
32	813.0	597	597
34	864.0	635	635
36	914.0	673	673
38	965.0	711	711
40	1 016.0	749	749
42	1 067.0	762	711
44	1 118.0	813	762
46	1 168.0	851	800
48	1 219.0	889	838

GENERAL NOTE: All dimensions are in millimeters.

NOTES:

(1) Outlet dimension M for NPS 26 and larger is recommended but not required.

(2) Dimensions applicable to crosses NPS 24 and smaller.

Dimensions of Reducing Outlet Tees and Reducing Outlet Crosses

ASME B16.9

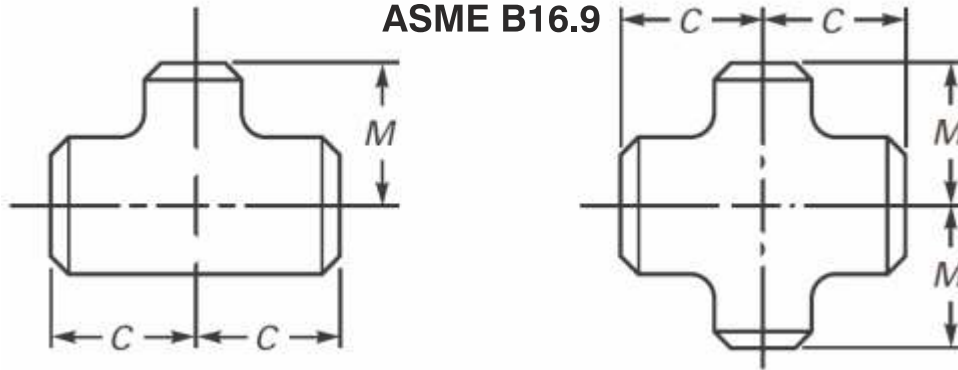

Nominal Pipe Size (NPS)	Outside Diameter at Bevel		Center-to-End	
	Run	Outlet	Run, C	Outlet, M [Note (1)]
1/2 x 1/2 x 3/8	21.3	17.3	25	25
1/2 x 1/2 x 1/4	21.3	13.7	25	25
3/4 x 3/4 x 1/2	26.7	21.3	29	29
3/4 x 3/4 x 3/8	26.7	17.3	29	29
1 x 1 x 3/4	33.4	26.7	38	38
1 x 1 x 1/2	33.4	21.3	38	38
1 1/4 x 1 1/4 x 1	42.2	33.4	48	48
1 1/4 x 1 1/4 x 3/4	42.2	26.7	48	48
1 1/4 x 1 1/4 x 1/2	42.2	21.3	48	48
1 1/2 x 1 1/2 x 1 1/4	48.3	42.2	57	57
1 1/2 x 1 1/2 x 1	48.3	33.4	57	57
1 1/2 x 1 1/2 x 3/4	48.3	26.7	57	57
1 1/2 x 1 1/2 x 1/2	48.3	21.3	57	57
2 x 2 x 1 1/2	60.3	48.3	64	60
2 x 2 x 1 1/4	60.3	42.2	64	57
2 x 2 x 1	60.3	33.4	64	51
2 x 2 x 3/4	60.3	26.7	64	44
2 1/2 x 2 1/2 x 2	73.0	60.3	76	70
2 1/2 x 2 1/2 x 1 1/2	73.0	48.3	76	67
2 1/2 x 2 1/2 x 1 1/4	73.0	42.2	76	64
2 1/2 x 2 1/2 x 1	73.0	33.4	76	57
3 x 3 x 2 1/2	88.9	73.0	86	83
3 x 3 x 2	88.9	60.3	86	76
3 x 3 x 1 1/2	88.9	48.3	86	73
3 x 3 x 1 1/4	88.9	42.2	86	70
3 1/2 x 3 1/2 x 3	101.6	88.9	95	92
3 1/2 x 3 1/2 x 2 1/2	101.6	73.0	95	89
3 1/2 x 3 1/2 x 2	101.6	60.3	95	83
3 1/2 x 3 1/2 x 1 1/2	101.6	48.3	95	79

Nominal Pipe Size (NPS)	Outside Diameter at Bevel		Center-to-End	
	Run	Outlet	Run, C	Outlet, M [Note (1)]
4 x 4 x 3 1/2	114.3	101.6	105	102
4 x 4 x 3	114.3	88.9	105	98
4 x 4 x 2 1/2	114.3	73.0	105	95
4 x 4 x 2	114.3	60.3	105	89
4 x 4 x 1 1/2	114.3	48.3	105	86
5 x 5 x 4	141.3	114.3	124	117
5 x 5 x 3 1/2	141.3	101.6	124	114
5 x 5 x 3	141.3	88.9	124	111
5 x 5 x 2 1/2	141.3	73.0	124	108
5 x 5 x 2	141.3	60.3	124	105
6 x 6 x 5	168.3	141.3	143	137
6 x 6 x 4	168.3	114.3	143	130
6 x 6 x 3 1/2	168.3	101.6	143	127
6 x 6 x 3	168.3	88.9	143	124
6 x 6 x 2 1/2	168.3	73.0	143	121
8 x 8 x 6	219.1	168.3	178	168
8 x 8 x 5	219.1	141.3	178	162
8 x 8 x 4	219.1	114.3	178	156
8 x 8 x 3 1/2	219.1	101.6	178	152
10 x 10 x 8	273.0	219.1	216	203
10 x 10 x 6	273.0	168.3	216	194
10 x 10 x 5	273.0	141.3	216	191
10 x 10 x 4	273.0	114.3	216	184
12 x 12 x 10	323.8	273.0	254	241
12 x 12 x 8	323.8	219.1	254	229
12 x 12 x 6	323.8	168.3	254	219
12 x 12 x 5	323.8	141.3	254	216
14 x 14 x 12	355.6	323.8	279	270
14 x 14 x 10	355.6	273.0	279	257
14 x 14 x 8	355.6	219.1	279	248
14 x 14 x 6	355.6	168.3	279	238

ASME B16.9

Dimensions of Reducing Outlet Tees and Reducing Outlet Crosses

Nominal Pipe Size (NPS)	Outside Diameter at Bevel		Center-to-End	
			Run, C	Outlet, M [Note (1)]
	Run	Outlet		
16 x 16 x 14	406.4	355.6	305	305
16 x 16 x 12	406.4	323.8	305	295
16 x 16 x 10	406.4	273.0	305	283
16 x 16 x 8	406.4	219.1	305	273
16 x 16 x 6	406.4	168.3	305	264
18 x 18 x 16	457.0	406.4	343	330
18 x 18 x 14	457.0	355.6	343	330
18 x 18 x 12	457.0	323.8	343	321
18 x 18 x 10	457.0	273.0	343	308
18 x 18 x 8	457.0	219.1	343	298
20 x 20 x 18	508.0	457.0	381	368
20 x 20 x 16	508.0	406.4	381	356
20 x 20 x 14	508.0	355.6	381	356
20 x 20 x 12	508.0	323.8	381	346
20 x 20 x 10	508.0	273.0	381	333
20 x 20 x 8	508.0	219.1	381	324
22 x 22 x 20	559.0	508.0	419	406
22 x 22 x 18	559.0	457.0	419	394
22 x 22 x 16	559.0	406.4	419	381
22 x 22 x 14	559.0	355.6	419	381
22 x 22 x 12	559.0	323.8	419	371
22 x 22 x 10	559.0	273.0	419	359
24 x 24 x 22	610.0	559.0	432	432
24 x 24 x 20	610.0	508.0	432	432
24 x 24 x 18	610.0	457.0	432	419
24 x 24 x 16	610.0	406.4	432	406
24 x 24 x 14	610.0	355.6	432	406
24 x 24 x 12	610.0	323.8	432	397
24 x 24 x 10	610.0	273.0	432	384
26 x 26 x 24	660.0	610.0	495	483
26 x 26 x 22	660.0	559.0	495	470
26 x 26 x 20	660.0	508.0	495	457
26 x 26 x 18	660.0	457.0	495	444
26 x 26 x 16	660.0	406.4	495	432
26 x 26 x 14	660.0	355.6	495	432
26 x 26 x 12	660.0	323.8	495	422

Nominal Pipe Size (NPS)	Outside Diameter at Bevel		Center-to-End	
			Run, C	Outlet, M [Note (1)]
	Run	Outlet		
28 x 28 x 26	711	660.0	521	521
28 x 28 x 24	711	610.0	521	508
28 x 28 x 22	711	559.0	521	495
28 x 28 x 20	711	508.0	521	483
28 x 28 x 18	711	457.0	521	470
28 x 28 x 16	711	406.4	521	457
28 x 28 x 14	711	355.6	521	457
28 x 28 x 12	711	323.8	521	448
30 x 30 x 28	762	711.0	559	546
30 x 30 x 26	762	660.0	559	546
30 x 30 x 24	762	610.0	559	533
30 x 30 x 22	762	559.0	559	521
30 x 30 x 20	762	508.0	559	508
30 x 30 x 18	762	457.0	559	495
30 x 30 x 16	762	406.4	559	483
30 x 30 x 14	762	355.6	559	483
30 x 30 x 12	762	323.8	559	473
30 x 30 x 10	762	273.0	559	460
32 x 32 x 30	813	762.0	597	584
32 x 32 x 28	813	711.0	597	572
32 x 32 x 26	813	660.0	597	572
32 x 32 x 24	813	610.0	597	559
32 x 32 x 22	813	559.0	597	546
32 x 32 x 20	813	508.0	597	533
32 x 32 x 18	813	457.0	597	521
32 x 32 x 16	813	406.4	597	508
32 x 32 x 14	813	355.6	597	508
34 x 34 x 32	864	813.0	635	622
34 x 34 x 30	864	762.0	635	610
34 x 34 x 28	864	711.0	635	597
34 x 34 x 26	864	660.0	635	597
34 x 34 x 24	864	610.0	635	584
34 x 34 x 22	864	559.0	635	572
34 x 34 x 20	864	508.0	635	559
34 x 34 x 18	864	457.0	635	546
34 x 34 x 16	864	406.4	635	533

Dimensions of Reducing Outlet and Tees and Reducing Outlet Crosses (Cont'd)

Nominal Pipe Size (NPS)	Outside Diameter at Bevel		Center-to-End		Nominal Pipe Size (NPS)	Outside Diameter at Bevel		Center-to-End	
	Run	Outlet	Run, C	Outlet, M [Note (1)]		Run	Outlet	Run, C	Outlet, M [Note (1)]
36 x 36 x 34	914	864.0	673	660	42 x 42 x 24	1 067	610.0	762	660
36 x 36 x 32	914	813.0	673	648	42 x 42 x 22	1 067	559.0	762	660
36 x 36 x 30	914	762.0	673	635	42 x 42 x 20	1 067	508.0	762	660
36 x 36 x 28	914	711.0	673	622	42 x 42 x 18	1 067	457.0	762	648
36 x 36 x 26	914	660.0	673	622	42 x 42 x 16	1 067	406.4	762	635
36 x 36 x 24	914	610.0	673	610	44 x 44 x 42	1 118	1 067.0	813	762
36 x 36 x 22	914	559.0	673	597	44 x 44 x 40	1 118	1 016.0	813	749
36 x 36 x 20	914	508.0	673	584	44 x 44 x 38	1 118	965.0	813	737
36 x 36 x 18	914	457.0	673	572	44 x 44 x 36	1 118	914.0	813	724
36 x 36 x 16	914	406.4	673	559	44 x 44 x 34	1 118	864.0	813	724
					44 x 44 x 32	1 118	813.0	813	711
38 x 38 x 36	965	914.0	711	711					
38 x 38 x 34	965	864.0	711	698	44 x 44 x 30	1 118	762.0	813	711
38 x 38 x 32	965	813.0	711	686	44 x 44 x 28	1 118	711.0	813	698
38 x 38 x 30	965	762.0	711	673	44 x 44 x 26	1 118	660.0	813	698
38 x 38 x 28	965	711.0	711	648	44 x 44 x 24	1 118	610.0	813	698
					44 x 44 x 22	1 118	559.0	813	686
38 x 38 x 26	965	660.0	711	648	44 x 44 x 20	1 118	508.0	813	686
38 x 38 x 24	965	610.0	711	635					
38 x 38 x 22	965	559.0	711	622	46 x 46 x 44	1 168	1 118.0	851	800
38 x 38 x 20	965	508.0	711	610	46 x 46 x 42	1 168	1 067.0	851	787
38 x 38 x 18	965	457.0	711	597	46 x 46 x 40	1 168	1 016.0	851	775
					46 x 46 x 38	1 168	965.0	851	762
40 x 40 x 38	1 016	965.0	749	749	46 x 46 x 36	1 168	914.0	851	762
40 x 40 x 36	1 016	914.0	749	737	46 x 46 x 34	1 168	864.0	851	749
40 x 40 x 34	1 016	864.0	749	724					
40 x 40 x 32	1 016	813.0	749	711	46 x 46 x 32	1 168	813.0	851	749
40 x 40 x 30	1 016	762.0	749	698	46 x 46 x 30	1 168	762.0	851	737
					46 x 46 x 28	1 168	711.0	851	737
40 x 40 x 28	1 016	711.0	749	673	46 x 46 x 26	1 168	660.0	851	737
40 x 40 x 26	1 016	660.0	749	673	46 x 46 x 24	1 168	610.0	851	724
40 x 40 x 24	1 016	610.0	749	660	46 x 46 x 22	1 168	559.0	851	724
40 x 40 x 22	1 016	559.0	749	648					
40 x 40 x 20	1 016	508.0	749	635	48 x 48 x 46	1 219	1 168.0	889	838
40 x 40 x 18	1 016	457.0	749	622	48 x 48 x 44	1 219	1 118.0	889	838
					48 x 48 x 42	1 219	1 067.0	889	813
42 x 42 x 40	1 067	1 016.0	762	711	48 x 48 x 40	1 219	1 016.0	889	813
42 x 42 x 38	1 067	968.0	762	711					
42 x 42 x 36	1 067	914.0	762	711	48 x 48 x 38	1 219	965.0	889	813
42 x 42 x 34	1 067	864.0	762	711	48 x 48 x 36	1 219	914.0	889	787
					48 x 48 x 34	1 219	864.0	889	787
42 x 42 x 32	1 067	813.0	762	711	48 x 48 x 32	1 219	813.0	889	787
42 x 42 x 30	1 067	762.0	762	711					
42 x 42 x 28	1 067	711.0	762	698	48 x 48 x 30	1 219	762.0	889	762
42 x 42 x 26	1 067	660.0	762	698	48 x 48 x 28	1 219	711.0	889	762
					48 x 48 x 26	1 219	660.0	889	762
					48 x 48 x 24	1 219	610.0	889	737
					48 x 48 x 22	1 219	559.0	889	737

GENERAL NOTE: All dimensions are in millimeters.

NOTE:

(1) Outlet dimension M for run sizes NPS 14 and larger is recommended but not required

ASME B16.9
Dimensions of Lap Joint Stub Ends

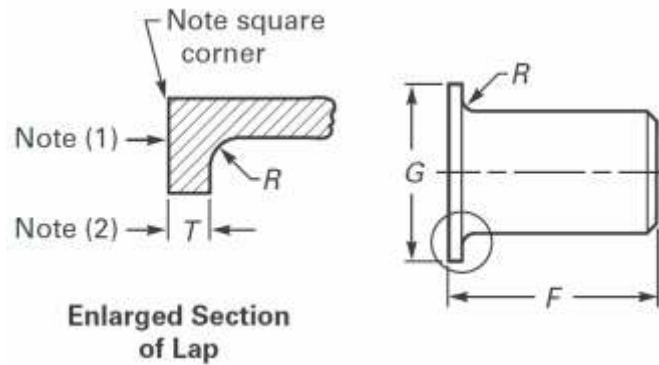

Nominal Pipe Size (NPS)	Outside Diameter of Barrel		Long Pattern Length, F [Note (3), (4)]	Short Pattern Length, F [Note (3), (4)]	Radius of Fillet, R [Note (5)]	Diameter of Lap, G [Note (6)]
	Max.	Min.				
1/2	22.8	20.5	76	51	3	35
3/4	28.1	25.9	76	51	3	43
1	35.0	32.6	102	51	3	51
1 1/4	43.6	41.4	102	51	5	64
1 1/2	49.9	47.5	102	51	6	73
2	62.4	59.5	152	64	8	92
2 1/2	75.3	72.2	152	64	8	105
3	91.3	88.1	152	64	10	127
3 1/2	104.0	100.8	152	76	10	140
4	116.7	113.5	152	76	11	157
5	144.3	140.5	203	76	11	186
6	171.3	167.5	203	89	13	216
8	222.1	218.3	203	102	13	270
10	277.2	272.3	254	127	13	324
12	328.0	323.1	254	152	13	381
14	359.9	354.8	305	152	13	413
16	411.0	405.6	305	152	13	470
18	462.0	456.0	305	152	13	533
20	514.0	507.0	305	152	13	584
22	565.0	558.0	305	152	13	641
24	616.0	609.0	305	152	13	692

GENERAL NOTES:

- (a) All dimensions are in millimeters.
- (b) Service conditions and joint construction often dictate stub end length requirements. Therefore, the purchaser must specify long or short pattern fitting when ordering.

NOTES:

- (1) Gasket face finish shall be in accordance with ASME B16.5 for raised face flanges.
- (2) The lap thickness T shall not be less than nominal pipe wall thickness.
- (3) When short pattern stub ends are used with larger flanges in Classes 300 and 600, with most sizes in Classes 900 and higher, and when long pattern stub ends are used with larger flanges in Classes 1500 and 2500, it may be necessary to increase the length of the stub ends in order to avoid covering the weld with the flange. Such increases in length shall be a matter of agreement between the manufacturer and purchaser.
- (4) When special facings such as tongue and groove, male and female, etc., are employed, additional lap thickness must be provided and such additional thickness shall be in addition to (not included in) the basic length F.
- (5) These dimensions conform to the radius established for lap joint flanges in ASME B16.5.
- (6) This dimension conforms to standard machined facings shown in ASME B16.5. The back face of the lap shall be machined to conform to the surface on which it seats. Where ring joint facings are to be applied, use dimension K as given in ASME B16.5.

Dimensions of Caps **ASME B16.9**

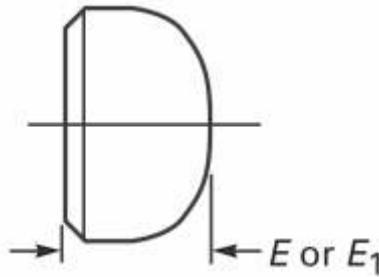

Nominal Pipe Size (NPS)	Outside Diameter at Bevel	Length, E [Note (1)]	Limiting Wall Thickness for Length, E	Length, E ₁ [Note (2)]
½	21.3	25	4.57	25
¾	26.7	25	3.81	25
1	33.4	38	4.57	38
1¼	42.2	38	4.83	38
1½	48.3	38	5.08	38
2	60.3	38	5.59	44
2½	73.0	38	7.11	51
3	88.9	51	7.62	64
3½	101.6	64	8.13	76
4	114.3	64	8.64	76
5	141.3	76	9.65	89
6	168.3	89	10.92	102
8	219.1	102	12.70	127
10	273.0	127	12.70	152
12	323.8	152	12.70	178
14	355.6	165	12.70	191
16	406.4	178	12.70	203
18	457.0	203	12.70	229
20	508.0	229	12.70	254
22	559.0	254	12.70	254
24	610.0	267	12.70	305
26	660.0	267
28	711.0	267
30	762.0	267
32	813.0	267
34	864.0	267
36	914.0	267
38	965.0	305
40	1 016.0	305
42	1 067.0	305
44	1 118.0	343
46	1 168.0	343
48	1 219.0	343

GENERAL NOTES:

- (a) All dimensions are in millimeters.
- (b) The shape of these caps shall be ellipsoidal and shall conform to the requirements given in the ASME Boiler and Pressure Vessel Code.

NOTES:

- (1) Length E applies for thickness not exceeding that given in column "Limiting Wall Thickness for Length, E."
- (2) Length E₁ applies for thickness greater than that given in column "Limiting Wall Thickness" for NPS 24 and smaller. For NPS 26 and larger, length E₁ shall be by agreement between the manufacturer and purchaser.

ASME B16.9 Dimensions of Reducers

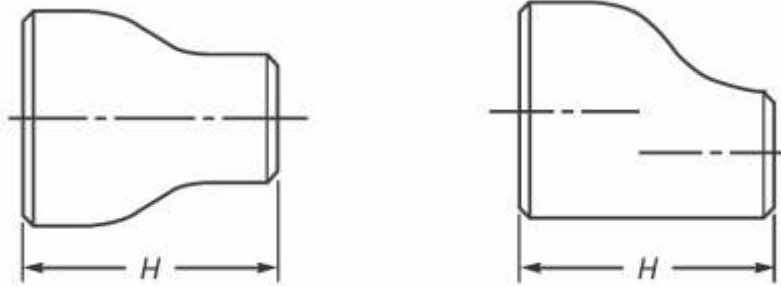

Nominal Pipe Size (NPS)	Outside Diameter at Bevel		End-to-End, H	Nominal Pipe Size (NPS)	Outside Diameter at Bevel		End-to-End, H
	Large End	Small End			Large End	Small End	
3/4 x 1/2	26.7	21.3	38	5 x 4	141.3	114.3	127
3/4 x 3/8	26.7	17.3	38	5 x 3 1/2	141.3	101.6	127
1 x 3/4	33.4	26.7	51	5 x 3	141.3	88.9	127
1 x 1/2	33.4	21.3	51	5 x 2 1/2	141.3	73.0	127
				5 x 2	141.3	60.3	127
1 1/4 x 1	42.2	33.4	51				
1 1/4 x 3/4	42.2	26.7	51	6 x 5	168.3	141.3	140
1 1/4 x 1/2	42.2	21.3	51	6 x 4	168.3	114.3	140
				6 x 3 1/2	168.3	101.6	140
1 1/2 x 1 1/4	48.3	42.2	64	6 x 3	168.3	88.9	140
1 1/2 x 1	48.3	33.4	64	6 x 2 1/2	168.3	73.0	140
1 1/2 x 3/4	48.3	26.7	64				
1 1/2 x 1/2	48.3	21.3	64	8 x 6	219.1	168.3	152
				8 x 5	219.1	141.3	152
2 x 1 1/2	60.3	48.3	76	8 x 4	219.1	114.3	152
2 x 1 1/4	60.3	42.2	76	8 x 3 1/2	219.1	101.6	152
2 x 1	60.3	33.4	76				
2 x 3/4	60.3	26.7	76	10 x 8	273.0	219.1	178
				10 x 6	273.0	168.3	178
2 1/2 x 2	73.0	60.3	89	10 x 5	273.0	141.3	178
2 1/2 x 1 1/2	73.0	48.3	89	10 x 4	273.0	114.3	178
2 1/2 x 1 1/4	73.0	42.2	89				
2 1/2 x 1	73.0	33.4	89	12 x 10	323.8	273.0	203
				12 x 8	323.8	219.1	203
3 x 2 1/2	88.9	73.0	89	12 x 6	323.8	168.3	203
3 x 2	88.9	60.3	89	12 x 5	323.8	141.3	203
3 x 1 1/2	88.9	48.3	89				
3 x 1 1/4	88.9	42.2	89	14 x 12	355.6	323.8	330
				14 x 10	355.6	273.0	330
3 1/2 x 3	101.6	88.9	102	14 x 8	355.6	219.1	330
3 1/2 x 2 1/2	101.6	73.0	102	14 x 6	355.6	168.3	330
3 1/2 x 2	101.6	60.3	102				
3 1/2 x 1 1/2	101.6	48.3	102	16 x 14	406.4	355.6	356
3 1/2 x 1 1/4	101.6	42.2	102	16 x 12	406.4	323.8	356
				16 x 10	406.4	273.0	356
4 x 3 1/2	114.3	101.6	102	16 x 8	406.4	219.1	356
4 x 3	114.3	88.9	102				
4 x 2 1/2	114.3	73.0	102	18 x 16	457	406.4	381
4 x 2	114.3	60.3	102	18 x 14	457	355.6	381
4 x 1 1/2	114.3	48.3	102	18 x 12	457	323.8	381
				18 x 10	457	273.0	381

ASME B16.9
Dimensions of Reducers (Cont'd)

Nominal Pipe Size (NPS)	Outside Diameter at Bevel		End-to-End, H	Nominal Pipe Size (NPS)	Outside Diameter at Bevel		End-to-End, H
	Large End	Small End			Large End	Small End	
20 x 18	508	457.0	508	36 x 34	914	864	610
20 x 16	508	406.4	508	36 x 32	914	813	610
20 x 14	508	355.6	508	36 x 30	914	762	610
20 x 12	508	323.8	508	36 x 26	914	660	610
				36 x 24	914	610	610
22 x 20	559	508.0	508				
22 x 18	559	457.0	508	38 x 36	965	914	610
22 x 16	559	406.4	508	38 x 34	965	864	610
22 x 14	559	355.4	508	38 x 32	965	813	610
				38 x 30	965	762	610
24 x 22	610	559.0	508	38 x 28	965	711	610
24 x 20	610	508.0	508	38 x 26	965	660	610
24 x 18	610	457.0	508				
24 x 16	610	406.4	508	40 x 38	1 016	965	610
				40 x 36	1 016	914	610
26 x 24	660	610.0	610	40 x 34	1 016	864	610
26 x 22	660	559.0	610	40 x 32	1 016	813	610
26 x 20	660	508.0	610	40 x 30	1 016	762	610
26 x 18	660	457.0	610				
				42 x 40	1 067	1 016	610
28 x 26	711	660.0	610	42 x 38	1 067	965	610
28 x 24	711	610.0	610	42 x 36	1 067	914	610
28 x 20	711	508.0	610	42 x 34	1 067	864	610
28 x 18	711	457.0	610	42 x 32	1 067	813	610
				42 x 30	1 067	762	610
30 x 28	762	711.0	610				
30 x 26	762	660.0	610	44 x 42	1 118	1 067	610
30 x 24	762	610.0	610	44 x 40	1 118	1 016	610
30 x 20	762	508.0	610	44 x 38	1 118	965	610
				44 x 36	1 118	914	610
32 x 30	813	762.0	610				
32 x 28	813	711.0	610	46 x 44	1 168	1 118	711
32 x 26	813	660.0	610	46 x 42	1 168	1 067	711
32 x 24	813	610.0	610	46 x 40	1 168	1 016	711
				46 x 38	1 168	965	711
34 x 32	864	813.0	610				
34 x 30	864	762.0	610	48 x 46	1 219	1 168	711
34 x 26	864	660.0	610	48 x 44	1 219	1 118	711
34 x 24	864	610.0	610	48 x 42	1 219	1 067	711
				48 x 40	1 219	1 016	711

GENERAL NOTES:

- (a) All dimensions are in millimeters.
- (b) While the figure illustrates a bell-shaped reducer, the use of a conical reducer is not prohibited.

ASME B16.9

Welding Bevels and Root Face

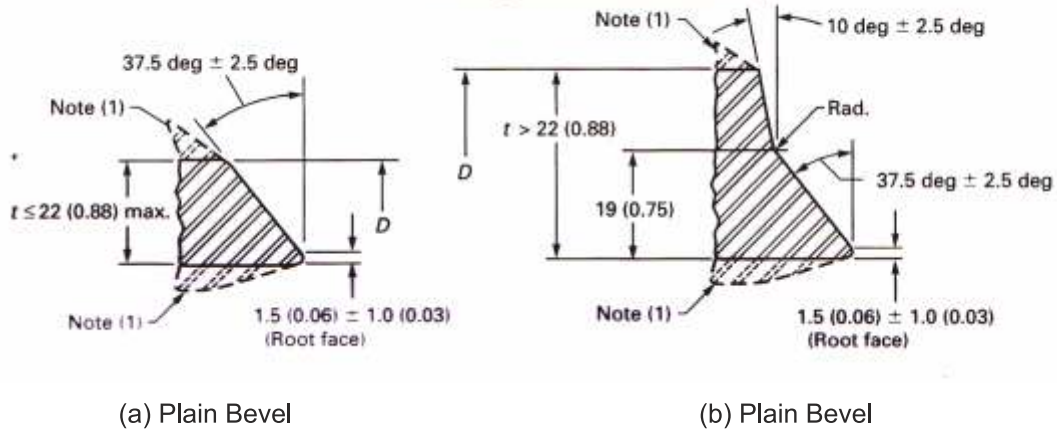

Nominal Wall Thickness, t

End Preparation

Less than x [Note (2)]
 x to 22 (0.88), inclusive
 More than 22 (0.88)

Cut square or slightly chamfer, at manufacturer's option (not illustrated)
 Plain bevel as in illustration (a) above
 Compound bevel as in illustration (b) above

GENERAL NOTES :

- (a) Dimensions in parentheses are in inches.
- (b) Other dimensions are in millimeters.

NOTES :

- (1) See section 8 and Fig. 1 For transition contours.
- (2) $x = 5$ (0.19) for carbon steel or Ferritic alloy steel and 3 (0.12) for austenitic alloy steel.



ASME B16.9
Tolerances

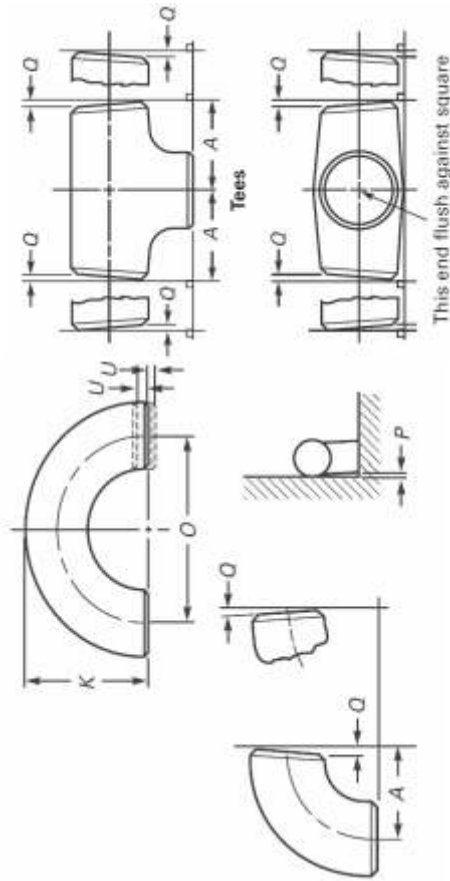

All Fittings [Notes (1) and (2)]		Center-to-End Dimensions			Overall Length of Reducers and Lap joint Stub Ends, F,H	Overall Length of Caps, E	180-deg Returns			
		90-deg and 45-deg long and Short Radius Elbows and Tees, A, B,C, M	3D Radius Elbows, A,B	Inside Diameter at End [Notes (3) and (5)]			Center-to-Center Dimensions, O	Back-to-Face Dimension, K	Alignment of Ends, U	
Nominal Pipe Size (NPS)	DN									
	15-65	+1.6, -0.8	0.8	2	2	3	6	1		
	80-90	1.6	1.6	2	2	3	6	1		
4	100	1.6	1.6	2	2	3	6	1		
	125-200	+2.4, -1.6	1.6	2	2	6	6	1		
10 to 18	250-450	+4.0, -3.2	3.2	2	2	6	10	2		
	500-600	+6.4, -4.8	4.8	2	2	6	10	2		
	650-750	+6.4, -4.8	4.8	3	5	10		
	800-1 200	+6.4, -4.8	4.8	5	5	10		

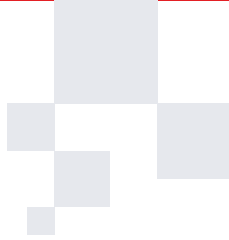

ASME B16.9

Tolerances (Cont'd)

Nominal /e (NPS)	Lap Joint Stub Ends [Note (6)]			Pipe Size (NPS)	Angularity Tolerances		
	DN	Outside of Lap, G	Fillet of Lap, R		Lap Thickness	DN	off Angle, Q
1/2 to 2 1/2	15-65	+0, -1	+0, -1	1/2 to 4	15-100	1	2
3 to 3 1/2	80-90	+0, -1	+0, -1	5 to 8	125-200	2	4
4	100	+0, -1	+0, -2	10 to 12	250-300	3	5
5 to 8	125-200	+0, -1	+0, -2	14 to 16	350-400	3	6
10 to 18	250-450	+0, -2	+0, -2	18 to 24	450-600	4	10
20 to 24	500-600	+0, -2	+0, -2	26 to 30	650-750	5	10
26 to 30	650-750	32 to 42	800-1 050	5	13
32 to 48	800-1200	44 to 48	1 100-1 200	5	19

GENERAL NOTES:

- All dimensions are in millimeters.
- Tolerances are equal plus and minus except as noted.

NOTES:

- The inside diameter and the nominal wall thicknesses at ends are to be specified by the purchaser.
- A minimum wall thickness of 87.5% applies unless the purchaser specifies a different wall thickness tolerance. See Fig. 1, Note (1)(a).
- Out-of-round is the sum of absolute values of plus and minus tolerances.
- This tolerance may not apply in localized areas of formed fittings where increased wall thickness is required to meet design requirements of para. 2.2.
- Unless otherwise specified by the purchaser, these tolerances apply to the nominal inside diameter, which equals the difference between the nominal outside diameter and twice the nominal wall thickness.
- See Dimension of lap joint stub Ends 9 for limiting dimensions of outside diameter of barrel.



Anupam metals India

Regd. Office: 24/1, 2nd Carpenter Street, Near C. P. Tank, Mumbai - 400004.
Tel: (+91-22) 2381 0301/ 2381 0302 | Fax: (+91-22) 2382 4625

Branch Office: G-39, DDA Flats, Behind Raghushree Market, Ajmeri Gate, Delhi - 110006.
Tel: (+91-11) 2323 3521 / 2323 9553 | Fax: (+91-11) 2323 6913

Email: info@anupammetals.com | Website: www.anupammetals.com